

OPTIONAL

**AUTOMATIC LUBRICATION SYSTEM**



WITH THIS SYSTEM IS POSSIBLE TO ENSURE A CORRECT NEBULIZATION'S TOOL.

**HIGH PRECISION LASER POINTMENT**

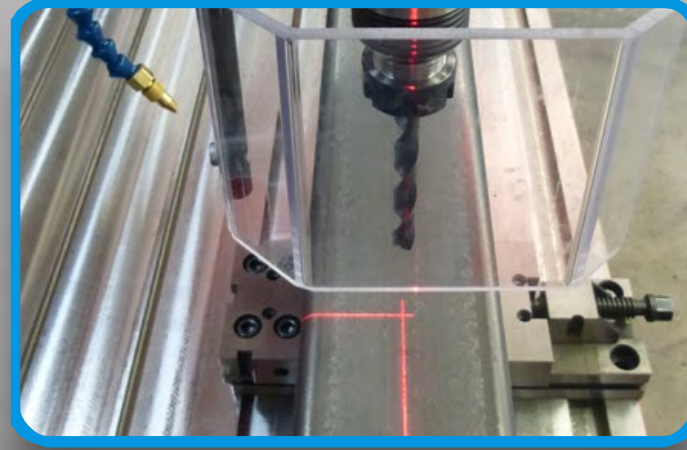

THIS SYSTEM ALLOWS YOU TO SEE PREVIOUSLY WHERE THE DRILLING WILL BE DONE.

**DEPTH SENSOR**

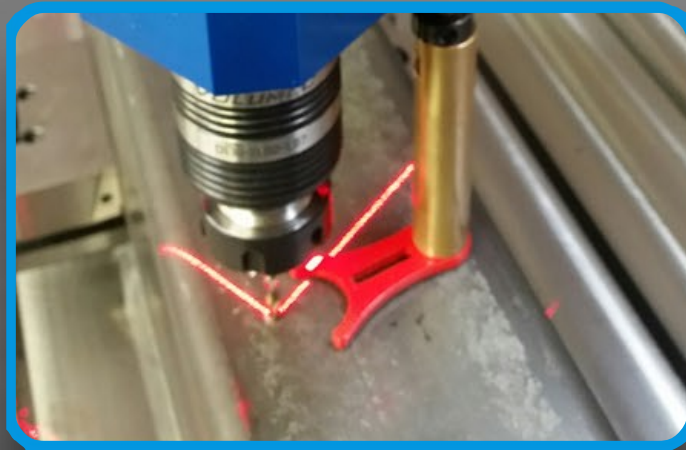

ALLOW TO SET THE DESIRE DRILLING-TAPPING-COUNTERSINKS DEPTH

**REFRIGERATION SYSTEM**



REFRIGERATION EMULSION PLANT WITH FLOW RATE OF 22 L/MIN.

TYPE OF BENCHES

OPTIMIZED STRUCTURAL BENCH FOR DRILLTRONIC WITH 30 MM REINFORCED BASE AND INTERNAL COMPARTMENT FOR TOOLS AND EQUIPMENT STORAGE.

AVAILABLE WITH A ROUGH TOP OR WITH WORKED T-SLOTS TOP AND REFRIGERATION SYSTEM PREDISPOSITION.

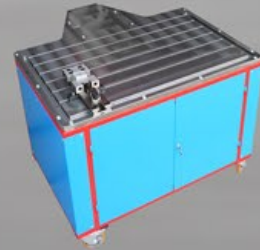

CODE	WORKING AREA	WORKBENCH WITH ADJUSTABLE HEIGHT	TYPE OF PLAN	ARRANGEMENT REFRIGERANT PREPARATION	WEIGHT
BDL128	1200x800 mm	750/850 mm	WORKING WITH T-SLOTS	YES	360 kg
BDG128	1200x800 mm	750/850 mm	ROUGH	NO	360 kg



CODE	WORKING AREA	WORKBENCH WITH ADJUSTABLE HEIGHT	TYPE OF PLAN	ARRANGEMENT REFRIGERANT PREPARATION	WEIGHT
BDL1810	1800x1000 mm	750/850 mm	WORKING WITH T-SLOTS	YES	650 kg
BDG1810	1800x1000 mm	750/850 mm	ROUGH	NO	650 kg

COLUMN WITH THE POSSIBILITY OF GROUND FIXING H=2000 mm



ALL DRILLTRONIC MODELS CAN BE EQUIPPED WITH A LIFTING COLUMN, THAT CAN BE FIX TO THE GROUND.

CODE	COLUMN'S HEIGHT	ARM RACE	HANDLING	BASE	TOTAL WEIGHT
CFT	2000 mm	715 mm	MANUAL (MOTORIZATION ON DEMAND)	300 X 300 mm	215 kg



VOLUME MEC®  
 VIA DEL MERCATO 5  
 31020 SERNAGLIA DELLA BATTAGLIA (TV) - ITALY  
 TEL. +39-0438-900299- FAX. +39-0438-1896510  
 C.F.- P.IVA: IT04029360262  
 E-MAIL: INFO@VOLUME.C.IT



Cesta na Brdo 85, 1000 Ljubljana  
 tel:+386 1 256 10 56, fax:+386 1 256 10 55  
 mailto:info@energe.si, http://www.energe.si



**Drilling and tapping arm machine**



**DRILLTRONIC**



# DRILLTRONIC

DRILLTRONIC IS THE ONLY INTEGRATED DRILLING AND TAPPING UNIT EQUIPPED WITH AN INNOVATIVE ARTICULATED ARM SYSTEM, THAT HAS BEEN DEVELOPED TO GIVE MAXIMUM WORKING FLEXIBILITY. THE STRUCTURE IS DESIGNED WITH A TECHNOLOGY THAT CAN PROVIDE FLUIDITY AND SPEEDNESS DURING THE PLACEMENTS, ENSURING RIGIDITY AND PRECISION DURING THE WORKING OPERATIONS.



WATCH THE VIDEO ▶



## ASSISTED CONTROL-SYSTEM VAPS - OPTIONAL



THE NEW CONTROL-SYSTEM VAPS (VOLUMEK<sup>®</sup> ASSISTED POSITIONING SYSTEM), IS AN OPERATOR TOUCH-SCREEN INTERFACE EASY AND INTUITIVE WITH WHICH IS POSSIBLE TO MAKE DRILLING AND TAPPING OPERATIONS, AT PRE-ESTABLISHED QUOTAS, WITHOUT ANY MANUAL TRACKING AS LIKE AS TRADITIONALS DRILLS

### THE PRINCIPAL FUNCTIONS ARE:

- QUICK IDENTIFICATION OF THE WORKPIECE POSITION (**ZERO SEARCH**).
- ASSISTED POSITIONING OF THE TOOL ON THE WORK SURFACE WITH **AUTOMATIC LOCKING AT THE REACHED MEASURE**.
- INTUITIVE PROGRAMMING OF DRILLING ON MORE POINTS (**X, Y, TOOL DIAMETER**).
- CREATION AND SAVING OF DRILLING CYCLES ON PARTS OF EVERY SHAPE
- AUTOMATIC CALCULATION OF **DRILLING ON FLANGES** BASED ON RADIUS AND ANGLE BETWEEN HOLES
- DRILLING PROGRAMMING IS ALSO POSSIBLE IN **AUTO-LEARNING MODE**
- **AUTOMATIC THREADING** BY SETTING PITCH AND DEPTH
- POSITIONING AND DRILLING ALSO WITH **MANUAL MODE**
- IMPORT / EXPORT DRILLING PROGRAMS VIA **USB**
- PC CONNECTION VIA **LAN**

MODEL	TYPE OF MOTOR	VOLTAGE (Volt)	SPEED ROTATION (rpm)	DRILLING CAPACITY WITH TWIST DRILL (mm)	DRILLING CAPACITY WITH CUTTER (mm)	TAPPING CAPACITY ON STEEL	MECHANICAL SPEED CHANGE	COURSE OF ADVANCEMENT	VERTICAL COURSE (mm)
DT131000	BRUSHLESS	200 -255 V 50/60 HZ	100 - 1000	∅ 3 - ∅ 13	∅ 20	M3 - M12	/	135	500
DTS161250	BRUSHLESS	200 -255 V 50/60 HZ	30 - 1250	∅ 3 - ∅ 16 - (∅ 20 ALL.)	∅ 30	M3 - M20	1	135	500
DT134500	BRUSHLESS	200 -255 V 50/60 HZ	125 - 4500	∅ 3 - ∅ 10	∅ 15	M3 - M8	1	135	500

### WORKING AREA

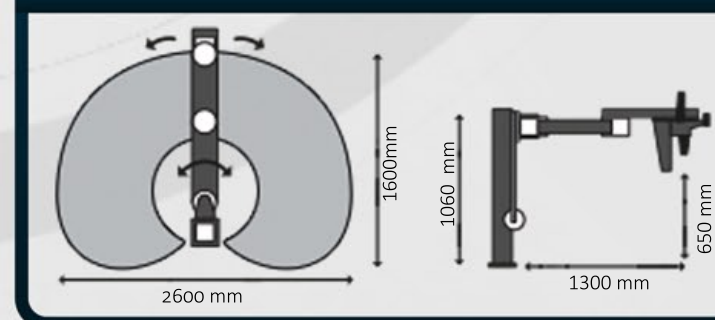

DRILLING TAPPING COUNTERSINKS

